

Reed Tracks Accessory Datasheet

SA13732

General Description

Tracks or Reed Tracks is the flexible interface layer between Stacks and your DUT (Device Under Test). It allows the connection of any line to any other line through a large relay multiplexer. When connected to the Core through the accessory bus, Tracks is a seamless expansion of the Core’s functionality. Just like the Core, it can be controlled using Python.

Reed Tracks is a matrix of reed relays that can be configured with any number of relays enabled. The relays may control signals or power, as all relays are rated for 200V and 1A. All inputs are galvanically isolated from each other as well as the control circuitry. There are eight banks of four relays each. Among the four relays, a common line connects all the relays. This allows for easy signal/power multiplexing, yet allows for flexibility for more obscure applications.

Reed Tracks is enclosed in a black anodized aluminum shell with LED indication of relay status on the top. Tracks mounts via 0.1” pitch pins as a component on a PCB, or alternately attaches to a breakout board. Electrically, Reed Tracks I/O are designed with industry-standard protection, and all relays are galvanically isolated from the control circuitry and each other.

Applications

- Automated Test Systems
- Design Verification Setups
- Muxing Networks

Features

- Stacks Accessory Bus Interface
- 200V Galvanic Isolation
- 0.5A/1A Switch/Hold Current
- Low Channel Switch Capacitance
- Low Channel Switch Leakage
- Addressable to control multiple units
- Rugged Aluminum Enclosure
- Ease of PCB Layout

Related Products

Description	Part Number
Reed Tracks Breakout Board	SA13720
Tracks Accessory	SA13816

Block Diagram

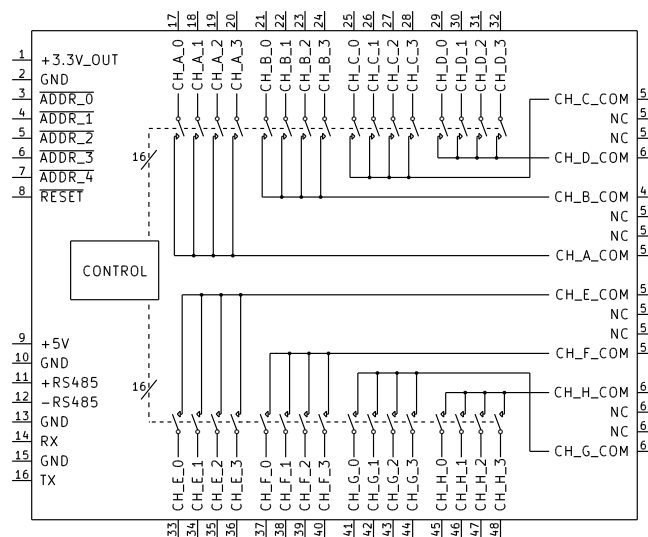

Figure 1: Block Diagram

Table of Contents

Pin Functionality Table.....2
 Electrical Specifications4
 Pinout Specifications5
 Mechanical Specifications6

Pin Functionality Table

Please refer to Figure 1.
 Reed Tracks Accessory pin-out detail:

Pin #	Function Name	Functionality
1	+3.3V_OUT	Direct connection to the internal +3.3V bias supply. This may be used to bias external circuits. Exceeding the rated current can cause unexpected operation. Do not drive this pin.
2,10,13,15	GND	Ground for signals and power.
3	$\overline{\text{ADDR}}_0$	LSB of the address selection pins. Connect to ground to set active, otherwise float the pin. This pin is read on power-up.
4	$\overline{\text{ADDR}}_1$	Bit 1 of the address selection lines. Connect to ground to set active, otherwise float the pin. This pin is read on power-up.
5	$\overline{\text{ADDR}}_2$	Bit 2 of the address selection lines. Connect to ground to set active, otherwise float the pin. This pin is read on power-up.
6	$\overline{\text{ADDR}}_3$	Bit 3 of the address selection lines. Connect to ground to set active, otherwise float the pin. This pin is read on power-up.
7	$\overline{\text{ADDR}}_4$	MSB of the address selection lines. Connect to ground to set active, otherwise float the pin. This pin is read on power-up.
8	$\overline{\text{RESET}}$	Connect to ground to reset the device, otherwise float the pin or pull up to +3.3V.
9	+5V	+5V device power. Typically connected to the Stacks Core’s 5V DUT Power.
11	+RS485	RS485 communication line. Idle high, active low line. Typically connected to the Stacks Core.
12	-RS485	RS485 communication line. Idle low, active high line. Typically connected to the Stacks Core.
14	RX	The console RX line with respect to the Reed Tracks device. Reserved for future use and can be left unconnected.
16	TX	The console TX line with respect to the Reed Tracks device. Reserved for future use and can be left unconnected.
17,18,19,20	CH_A_0-3	Bank A reed relay output contacts. These are normally open and can be independently controlled.
21,22,23,24	CH_B_0-3	Bank B reed relay output contacts. These are normally open and can be independently controlled.
25,26,27,28	CH_C_0-3	Bank C reed relay output contacts. These are normally open and can be independently controlled.
29,30,31,32	CH_D_0-3	Bank D reed relay output contacts. These are normally open and can be independently controlled.
33,34,35,36	CH_E_0-3	Bank E reed relay output contacts. These are normally open and can be independently controlled.
37,38,39,40	CH_F_0-3	Bank F reed relay output contacts. These are normally open and can be independently controlled.
41,42,43,44	CH_G_0-3	Bank G reed relay output contacts. These are normally open and can be independently controlled.

Pin #	Function Name	Functionality
45,46,47,48	CH_H_0-3	Bank H reed relay output contacts. These are normally open and can be independently controlled.
52	CH_A_COM	The common pole for bank A reed relay contacts.
49	CH_B_COM	The common pole for bank B reed relay contacts.
57	CH_C_COM	The common pole for bank C reed relay contacts.
60	CH_D_COM	The common pole for bank D reed relay contacts.
53	CH_E_COM	The common pole for bank E reed relay contacts.
56	CH_F_COM	The common pole for bank F reed relay contacts.
64	CH_G_COM	The common pole for bank G reed relay contacts.
61	CH_H_COM	The common pole for bank H reed relay contacts.
50,51,54,55, 58,59,62,63	NC	These are not connected inside the device to allow for sufficient voltage standoff clearance between adjacent common pins.

Electrical Specifications

Absolute Maximum Ratings⁽¹⁾

T_A = 25C, unless otherwise specified.

+5V to GND	-0.3V to 6.35V	ADDR_0 – 4 to GND.....	-7.0V to 7.0V
+3.3V _{OUT} to GND	-0.3V to 3.6V	Channel to Channel	250VDC/peak AC
RX to GND.....	-7.0V to 7.0V	Channel to Common.....	250VDC/peak AC
TX to GND.....	-7.0V to 7.0V	Channel to GND	250VDC/peak AC
RESET to GND.....	-7.0V to 7.0V	Storage Temp Range	0°C to +70°C
+RS485 to GND	-27.0V to 27.0V	Operation Temp Range.....	0°C to +50°C
-RS485 to GND	-27.0V to 27.0V		

(1) Stresses beyond those listed may cause permanent device damage. Functional operation range of the device is defined in Recommended Operating Ratings or Electrical Characteristics. Exposure to absolute max ratings for extended periods may reduce device reliability.

Recommended Operating Ratings

T_A = 25C, unless otherwise specified.

Parameter	Conditions	Min	Typ	Max	Unit
+5V, V _{SUPPLY}	Continuous	4.5	-	5.35	V
+3.3V _{OUT} Current	Continuous	-	-	25	mA
Channel to Channel Voltage ⁽¹⁾	Continuous	-200	-	200	V _{DC} /AC _{PEAK}
Channel to GND	Continuous	-200	-	200	V _{DC} /AC _{PEAK}

(1) Any combination of channel to channel or common within the same bank of 4 relays

Electrical Characteristics⁽¹⁾

T_A = 25C, V_{SUPPLY} = 5V, unless otherwise specified.

Parameter	Symbol	Conditions	Min	Typ	Max	Unit
OUTPUT						
+3.3V Output	+3.3V _{OUT}	I _{OUT} = 0	3.1	3.35	3.5	V
CHANNEL OUTPUTS						
Switch Voltage	V _{SW}	Max DC/peak AC resistive	-	-	200	V
Switching Current	I _{SW}	Max DC/peak AC resistive	-	-	0.5	A
Carry Current	I _{HOLD}	Current applied only when the switch is closed	-	-	1.0	A
Switch Resistance	R _{SW}	I = 10mA	-	0.2	-	Ω
Channel to Channel Insulation Resistance	IR	100V	-	10 ¹⁰	-	Ω
Channel to Channel Capacitance	C _(OFF)		-	0.7	-	pF
Switch Time	T _{SW}	Once the switch command is received from the accessory bus	-	1	-	ms
Switch Contact Seebeck Voltage		25C	-	±25	-	uV
Switch Life Expectancy			-	10 ⁸	-	Ops.
RS485 DRIVER						
Steady-state Differential Output Voltage	V _{O(SS)}	No load	3.3	4.2	5.3	V
		R _{TERM} = 60Ω	1.8	2.5	-	

(1) As designed and characterized, not fully tested in production unless otherwise specified.

