

Analog Deck

SA13730

General Description

The Analog Deck is the hub for measurement and sensing. It has a myriad of features that are designed for working with precision analog measurement. When connected to the Core, the Analog Deck is a seamless expansion of the Core’s functionality. Just like the Core, it can be controlled using Python.

The Analog Deck provides 6 digit DVM functionality on 7 isolated channels of measurement up to $\pm 240V$, as well as a $\pm 500mA$ floating current measurement. The 24-bit ADC circuitry is temperature-controlled for maximum stability. Isolation and measurement switching among channels is achieved in near 1ms using a high speed solid-state mux. The Analog Deck has a Source/Meter and Negative Power DAC that can be used to sweep a DUT (Device Under Test) input voltage during test. It provides a precision 5.00V reference as well as a 16-bit 1MSPS arbitrary waveform generator to create any necessary stimulus. It also has some general-purpose 3.3V and 5V digital I/O, isolated inputs, relays, and solenoid drivers.

A full bodied hard anodized aluminum enclosure provides physical protection for the Analog Deck. Electrically, the Analog Deck I/O are designed with industry-standard protection.



Applications

- Automated Test Systems
- Design Verification
- Rapid Prototyping

Features

- 6 channel, 6 digit, DVM
- 1 500mA, 6 digit Current Meter
- 1 16bit, 1MSPS, Arbitrary Waveform Generator
- 1 Positive Source Meter
- 1 Negative Power DAC
- 2 Power Meters
- 2 General Purpose Solid-state Relays
- 2 General Purpose Isolated Inputs
- 10 General Purpose DIOs

Related Products

Description	Part Number
Analog Breakout Board	SA13714
Stacks Core	SA13729

Rear Panel Connection

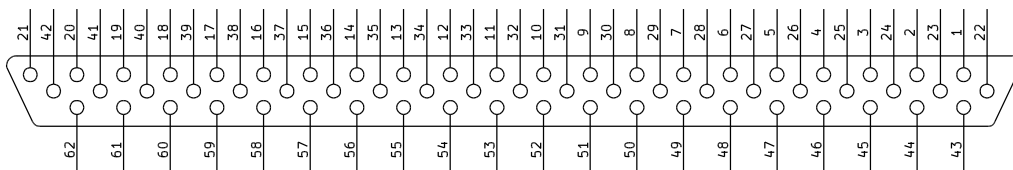

Figure 1: Connector Diagram

Table of Contents

Pin Functionality Table.....	2
DMM.....	5
+5.0V REF.....	8
Waveform Generator.....	9
Source/Meter.....	10
Negative Power DAC.....	11
Power Meters.....	12
DIOs.....	13
Isolated Input.....	14
Solid State Relay.....	15
Solenoid Driver.....	16
AC Measurement.....	17

Pin Functionality Table

Please refer to Figure 1.

Analog Deck DC-62 Connector Pin Functionality Chart:

Pin #	Function Name	Functionality
1	SOURCEMETER	Output range from 0 to 10V. Outputs 1A continuous from 5 - 10Vout, 0.5A continuous from 0 - 5Vout.
2	NEGATIVE_POWERDAC	12-bit buffered DAC, output range from -10V to 0V. Outputs 50mA.
3	-POWERMETER1_CURRENT	Negative input for Power Meter 1 current channel. The range is $\pm 1.5A$.
4	+POWERMETER1_CURRENT	Positive input for Power Meter 1 current channel. The range is $\pm 1.5A$.
5	-POWERMETER1_VOLTAGE	Negative input for Power Meter 1 voltage channel. The range is $\pm 13.5V$.
6	+POWERMETER1_VOLTAGE	Positive input for Power Meter 1 voltage channel. The range is $\pm 13.5V$.
7	-POWERMETER0_CURRENT	Negative input for Power Meter 0 current channel. The range is $\pm 150mA$.
8	+POWERMETER0_CURRENT	Positive input for Power Meter 0 current channel. The range is $\pm 150mA$.
9	-POWERMETER0_VOLTAGE	Negative input for Power Meter 0 voltage channel. The range is $\pm 13.5V$.
10	+POWERMETER0_VOLTAGE	Positive input for Power Meter 0 voltage channel. The range is $\pm 13.5V$.
11	+DMM_ICH6	Floating 24-bit 14kSPS ADC input channel. The range is $\pm 500mA$. May be $\pm 150V$ from Stacks GND.
12	- DMM_ICH6	Floating 24-bit 14kSPS ADC input channel. The range is $\pm 500mA$. May be $\pm 150V$ from Stacks GND.
13	GND	Ground for signals and power.
14	-DMM_VCH5	Floating 24-bit 14kSPS ADC input channel. May be $\pm 150V$ from Stacks GND, and may be $\pm 250V$ from the complimentary input.
15	+DMM_VCH5	Floating 24-bit 14kSPS ADC input channel. May be $\pm 150V$ from Stacks GND, and may be $\pm 250V$ from the complimentary input.

Pin #	Function Name	Functionality
16	-DMM_VCH2	Floating 24-bit 14kSPS ADC input channel. May be $\pm 150V$ from Stacks GND, and may be $\pm 250V$ from the complimentary input.
17	+DMM_VCH2	Floating 24-bit 14kSPS ADC input channel. May be $\pm 150V$ from Stacks GND, and may be $\pm 250V$ from the complimentary input.
18	-DMM_VCH0	Floating 24-bit 14kSPS ADC input channel. May be $\pm 150V$ from Stacks GND, and may be $\pm 250V$ from the complimentary input.
19	+DMM_VCH0	Floating 24-bit 14kSPS ADC input channel. May be $\pm 150V$ from Stacks GND, and may be $\pm 250V$ from the complimentary input.
20	NC	No internal connection for voltage isolation.
21	-DMM_VCH7HV	Floating 24-bit 14kSPS ADC input channel. This channel is isolated from the DMM input mux with a mechanical relay to increase voltage transient tolerance and decrease leakage current.
22	GND	Ground for signals and power.
23	DIO_7	Digital Input/Output. Configurable as +3.3V or +5V logic level
24	DIO_6	Digital Input/Output. Configurable as +3.3V or +5V logic level
25	DIO_5	Digital Input/Output. Configurable as +3.3V or +5V logic level
26	DIO_4	Digital Input/Output. Configurable as +3.3V or +5V logic level
27	DIO_3	Digital Input/Output. Configurable as +3.3V or +5V logic level
28	DIO_2	Digital Input/Output. Configurable as +3.3V or +5V logic level
29	DIO_1	Digital Input/Output. Configurable as +3.3V or +5V logic level
30	DIO_0	Digital Input/Output. Configurable as +3.3V or +5V logic level
31	WAVE_GEN_RTN_SENSE	Remote ground reference sense line for the Waveform Generator.
32	WAVE_GEN_OUT	Waveform Generator output. The range is $\pm 5V$ differential when WAVE_GEN_RTN_SENSE is connected and $\pm 10V$ single ended when WAVE_GEN_RTN_SENSE is floating.
33	GND	Ground for signals and power.
34	GND	Ground for signals and power.
35	GND	Ground for signals and power.
36	ISOLATED_INPUT_1	General purpose input, isolated to $\pm 60V$ from Stacks GND. May be driven up to +48V with respect to its RTN.
37	ISOLATED_INPUT_0	General purpose input, isolated to $\pm 60V$ from Stacks GND. May be driven up to +48V with respect to its RTN.
38	-DMM_VCH1	Floating 24-bit 14kSPS ADC input channel. May be $\pm 150V$ from Stacks GND, and may be $\pm 250V$ from the complimentary input.
39	+DMM_VCH1	Floating 24-bit 14kSPS ADC input channel. May be $\pm 150V$ from Stacks GND, and may be $\pm 250V$ from the complimentary input.
40	-DMM_VCH3	Floating 24-bit 14kSPS ADC input channel. May be $\pm 150V$ from Stacks GND, and may be $\pm 250V$ from the complimentary input.
41	NC	No internal connection for voltage isolation.
42	NC	No internal connection for voltage isolation.

Pin #	Function Name	Functionality
43	GND	Ground for signals and power.
44	SOLENOID_DRIVER_3	Solenoid Driver. Low-side switch with built-in clamping for inductive loads such as solenoids or relays.
45	SOLENOID_DRIVER_2	Solenoid Driver. Low-side switch with built-in clamping for inductive loads such as solenoids or relays.
46	RELAY1_SSR_COM	DC solid-state relay Common. May be used for AC or DC. Tolerant to $\pm 48\text{VDC}$ from contact A to contact B. Tolerant to $\pm 60\text{V}$ from Stack GND.
47	RELAY1_SSR_NO	DC solid-state relay Normally Open. May be used for AC or DC. Tolerant to $\pm 48\text{VDC}$ from contact A to contact B. Tolerant to $\pm 60\text{V}$ from Stack GND.
48	RELAY0_SSR_COM	DC solid-state relay Common. May be used for AC or DC. Tolerant to $\pm 48\text{VDC}$ from contact A to contact B. Tolerant to $\pm 60\text{V}$ from Stack GND.
49	RELAY0_SSR_NO	DC solid-state relay Normally Open. May be used for AC or DC. Tolerant to $\pm 48\text{VDC}$ from contact A to contact B. Tolerant to $\pm 60\text{V}$ from Stack GND.
50	SOLENOID_DRIVER_1	Solenoid Driver. Low-side switch with built-in clamping for inductive loads such as solenoids or relays.
51	SOLENOID_DRIVER_0	Solenoid Driver. Low-side switch with built-in clamping for inductive loads such as solenoids or relays.
52	+5.0VREF_OUT	Precision 5.00V reference.
53	GND	Ground for signals and power.
54	AC_MEAS_RTN	Return for AC Measurement
55	AC_MEAS	AC Measurement input. The range is $\pm 45\text{V}$ common mode and $\pm 300\text{mVpk}$ differential.
56	ISOLATED_INPUT_1_RTN	Isolated input return.
57	ISOLATED_INPUT_0_RTN	Isolated input return.
58	-DMM_VCH4	Floating 24-bit 14kSPS ADC input channel. May be $\pm 150\text{V}$ from Stacks GND, and may be $\pm 250\text{V}$ from the complimentary input.
59	+DMM_VCH4	Floating 24-bit 14kSPS ADC input channel. May be $\pm 150\text{V}$ from Stacks GND, and may be $\pm 250\text{V}$ from the complimentary input.
60	+DMM_VCH3	Floating 24-bit 14kSPS ADC input channel. May be $\pm 150\text{V}$ from Stacks GND, and may be $\pm 250\text{V}$ from the complimentary input.
61	NC	No internal connection for voltage isolation.
62	+DMM_VCH7HV	Floating 24-bit 14kSPS ADC input channel. This channel is isolated from the DMM input mux with a mechanical relay to increase voltage transient tolerance and decrease leakage current.
SHD	SHIELD	Connector shield is connected to chassis, and is capacitively coupled to GND though 1000V capacitors.

DMM

The DMM consists of one high-accuracy measurement unit connected via muxing to 6 voltage channels and one current channel. Channels 0-5 are voltage channels that employ solid-state muxing for rapid channel switching. Channel 6 is a current channel that also employs solid-state muxing. Channel 7 employs a mechanical relay, which is slower, but offers lower leakage and higher voltage. See the Functional Block Diagram for more details.

Applicable Pins: DC-62 pins 11, 12, 14 – 19, 21, 36 – 40, 58 – 60, 62.

Absolute Maximum Ratings⁽¹⁾⁽²⁾⁽³⁾

T_A = 25C, unless otherwise specified.

Description	Rating
Channel 0 – 6, pins ±DMM_VCH0-5, ±DMM_ICH6	
Applied Voltage V _{PIN-TO-PIN} ⁽⁴⁾⁽⁵⁾	±300V
Applied Voltage V _{POSITIVE-PIN-TO-GND} ⁽⁴⁾⁽⁶⁾	±300V
Applied Voltage V _{NEGATIVE-PIN-TO-GND} ⁽⁴⁾⁽⁷⁾	±150V
Channel 7, pins ±DMM_CH7_HV	
Applied Voltage V _{PIN-TO-PIN} ⁽⁴⁾⁽⁸⁾	±350V
Applied Voltage V _{POSITIVE-TO-GND} ⁽⁴⁾⁽⁹⁾	±350V
Applied Voltage V _{NEGATIVE-TO-GND} ⁽⁴⁾⁽¹⁰⁾	±150V
Applied Voltage V _{POSITIVE} to Channel 0-6 pins ⁽⁴⁾⁽¹¹⁾	±360V
Channel 6	
Applied Current from +DMM_ICH6 to -DMM_ICH6 ⁽¹²⁾	±800mA

- (1) Stresses beyond those listed may cause permanent device damage. Functional operation range of the device is defined in Recommended Operating Ratings or Electrical Characteristics. Exposure to absolute max ratings for extended periods may reduce device reliability.
- (2) As designed and characterized, not fully tested in production.
- (3) Voltages are relative to DC-62 D-sub GND pins unless otherwise specified.
- (4) Overvoltage spikes exceeding these voltages may cause irreversible damage to the device
- (5) Applicable pins are DC-62 D-sub pins 11, 12, 14, 15, 16, 17, 18, 19, 38, 39, 40, 58, 59, 60
- (6) Applicable pins are DC-62 D-sub pins 11, 15, 17, 19, 39, 59, 60
- (7) Applicable pins are DC-62 D-sub pins 12, 14, 16, 18, 38, 40, 58
- (8) Applicable pins are DC-62 D-sub pins 21, 62
- (9) Applicable pin is DC-62 D-sub pin 62
- (10) Applicable pin is DC-62 D-sub pin 21
- (11) Applicable “V_{POSITIVE}” pin is DC-62 D-sub pin 62. Applicable “Channel 0-6 pins” are DC-62 D-sub pins 11, 12, 14, 15, 16, 17, 18, 19, 38, 39, 40, 58, 59, 60
- (12) Applicable pins are DC-62 D-sub pins 11, 12

Recommended Operating Ratings

T_A = 25C, unless otherwise specified.

Parameter	Conditions	Min	Typ	Max	Unit
Current Input Range (Channel 6)		-500	-	500	mA
Voltage Input Range (All Channels)	Per the absolute max ratings, a voltage that can be safely applied in any pin configuration is ±150V . For voltages outside this range, refer to the Absolute Maximum Ratings.				

Electrical Characteristics⁽²⁾

T_A = 25C, V_{SUPPLY} = 20V, unless otherwise specified.

Parameter	Symbol	Conditions	Min	Typ	Max	Unit
Calibrated Voltage Reading Range ⁽⁴⁾	V _{RANGE}		-240	-	240	V
Calibrated Current Reading Range ⁽⁴⁾	I _{RANGE}		-200	-	200	mA
Input Impedance	R _{IN}	Channel Inactive	-	>10 ⁹	-	Ω
		Channel Active ⁽⁴⁾	9.8	10.0	10.2	MΩ
Input Capacitance (CH0-6)	C _{OFF}	Channel Inactive, V _{IN} = ±300V ⁽⁴⁾	-	20	-	pF
Input Leakage Current (CH0-6)	I _{OFF}	Channel Inactive, V _{IN} = ±300V ⁽⁴⁾	-	0.6	100	nA
Input Capacitance (CH7)	C _{OFF}	Channel Inactive, V _{IN} = ±300V ⁽⁴⁾	-	1	-	pF

Mux Transition Time (CH0-6)	T _{SW}	-	-	3	ms
Mux Transition Time (CH7)	T _{SW}	-	-	8.5	ms
Channel 6 Burden Resistor	R _{BURDEN}	0.98	1	1.02	Ω

- (1) Parameter 100% production tested at T_A = 25C
- (2) As designed and characterized, not fully tested in production unless otherwise specified.
- (3) Factory calibrated.
- (4) V_{IN} indicates the voltage applied between the positive and negative terminal of a single channel.
- (5) Applicable pins are DC-62 D-sub pins 12, 14, 16, 18, 21, 38, 40, 58

Accuracy Specifications⁽²⁾⁽⁴⁾

T_A = 25C or T_{CAL} ±5C, V_{SUPPLY} = 20V, unless otherwise specified.

Function	Range	1 Year ⁽¹⁾
DC Voltage ⁽³⁾ (CH0-5)	2.4V	0.014 + 0.0024
	24V	0.016 + 0.0024
	120V	0.020 + 0.0048
DC Current ⁽³⁾ (CH6)	200mA	0.020 + 0.0024
DC Voltage (CH7)	2.4V	0.014 + 0.0064
	24V	0.016 + 0.0064
	240V	0.020 + 0.0064

- (1) Accuracy Specifications: ±(% of reading + % of range)
- (2) Specifications are after a 60-minute warm-up time.
- (3) Add 40ppm error when using CH7.
- (4) With auto-zero enabled.

Performance Characteristics⁽²⁾

T_A = 25C, V_{SUPPLY} = 20V, unless otherwise specified.

Parameter	Symbol	Conditions	Min	Typ	Max	Unit
Sample Rate Accuracy				±0.2		%
		Across Temperature			±2	%
Bandwidth, -3dB, SINC1 filter		Data Rate: 10sps		4.3		Hz
		Data Rate: 16.6sps		7.3		Hz
		Data Rate: 50sps		22		Hz
		Data Rate: 60sps		27		Hz
		Data Rate: 400sps		177		Hz
		Data Rate: 1200sps		525		Hz
		Data Rate: 3600sps		1440		Hz
		Data Rate: 14400sps		2930		Hz
Bandwidth, -3dB, SINC2 filter		Data Rate: 10sps		3.1		Hz
		Data Rate: 16.6sps		5.2		Hz
		Data Rate: 50sps		16		Hz
		Data Rate: 60sps		19		Hz
		Data Rate: 400sps		127		Hz
		Data Rate: 1200sps		380		Hz
		Data Rate: 3600sps		1100		Hz
		Data Rate: 14400sps		2930		Hz

- (2) As designed and characterized, not fully tested in production unless otherwise specified.

DMM Diagram

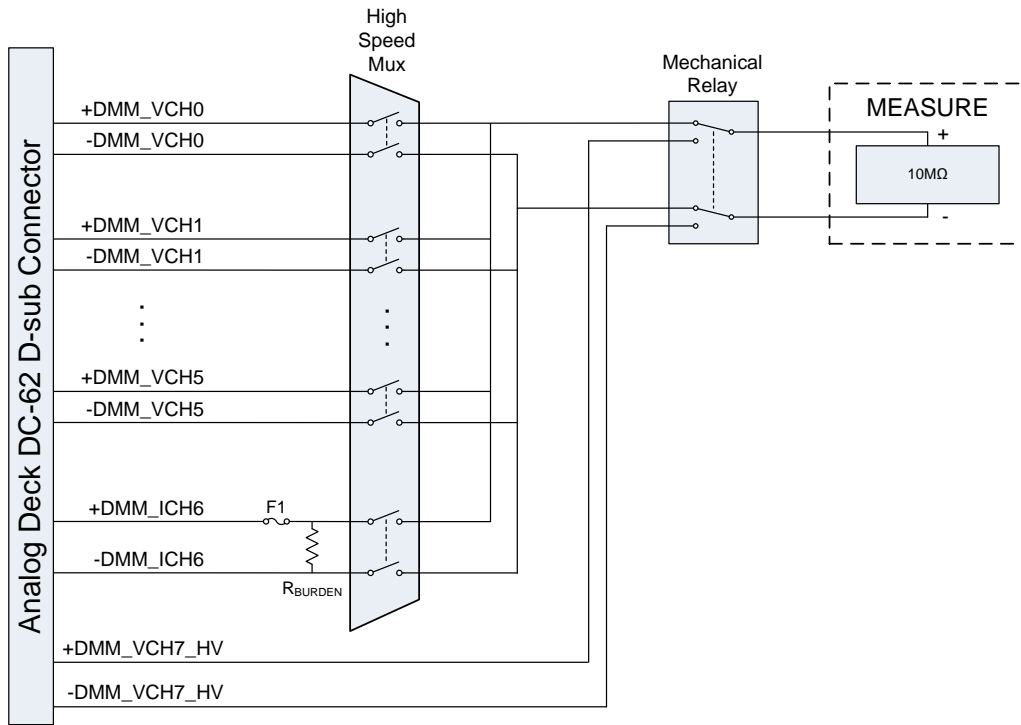

Figure 2: Functional Block Diagram of DMM

+5.0V REF

A precision +5.000 reference is made available to the user through the DC-62 D-sub connector. This can be used as a reference for any off-board user circuitry.

This is a generic, precision, low noise +5.000VDC reference for general purpose. This reference is single-ended with respect to the analog deck ground. If this reference is connected to a non-isolated circuit, the circuit should utilize a differential amplifier to maintain accuracy. DC-62 pin 53 is a ground pin that is kelvin connected internally to the +5.0V reference.

Applicable Pins: DC-62 pin 52.

Absolute Maximum Ratings⁽¹⁾⁽²⁾⁽³⁾

T_A = 25C, unless otherwise specified.

Description	Rating
Continuous Applied Voltage ⁽⁴⁾	-0.3V to +6V
Output Short Circuit	Continuous
Positive Clamping Current, I _{+CLAMP} ⁽⁵⁾	-10mA
Negative Clamping Current, I _{-CLAMP} ⁽⁶⁾	10mA

- (1) Stresses beyond those listed may cause permanent device damage. Functional operation range of the device is defined in Recommended Operating Ratings or Electrical Characteristics. Exposure to absolute max ratings for extended periods may reduce device reliability.
- (2) Voltages are relative to GND pins.
- (3) As designed and characterized, not fully tested in production.
- (4) Applied voltage ratings may be exceeded if the clamping current ratings are observed.
- (5) Input terminal is TVS-clamped for input voltages above +5V. Signals that swing more than 0.3V above +5V should be current limited to less than I_{CLAMP}.
- (6) Input terminal is diode-clamped to GND for input voltages that swing below GND. Signals that swing more than 0.3V below GND should be current limited to less than I_{CLAMP}.

Recommended Operating Ratings

T_A = 25C, unless otherwise specified.

Parameter	Conditions	Min	Typ	Max	Unit
Output Voltage, V _{OUT}	Continuous	0	-	5	V
Output Current, I _{OUT}	Continuous	I _{-OUT}		I _{+OUT}	mA

Electrical Characteristics⁽²⁾

T_A = 25C, V_{SUPPLY} = 20V, unless otherwise specified.

Parameter	Symbol	Conditions	Min	Typ	Max	Unit
Output Current	I _{+OUT}	Sourcing	10	16	-	mA
	I _{-OUT}	Sinking	10	17	-	
Output Voltage	V _{OUT}		4.997	5.0000	5.003	V
Output Voltage Noise	V _{NOISE}	f = 0.1Hz to 10Hz	-	15	-	μV _{PP}
Capacitive Load Drive	C _{LOAD}		-	1	-	nF

- (1) Parameter 100% production tested at T_A = 25C
- (2) As designed and characterized, not fully tested in production unless otherwise specified.

Waveform Generator

A precision 16 bit, -5V to +5V Waveform Generator is available.

Return Sense: The Waveform Generator provides a WAVEGEN_RTN_SENSE that can be routed to the negative of the load. The WAVEGEN_RTN_SENSE will compensate for ground loop currents between the deck and the load. WAVEGEN_RTN_SENSE may be floated up to V_{CM} from GND.

Applicable Pins: DC-62 pins 31 and 32.

Absolute Maximum Ratings⁽¹⁾⁽²⁾⁽³⁾

$T_A = 25C$, unless otherwise specified.

Description	Rating
Continuous Applied Voltage ⁽⁴⁾	-10V to +10V
Clamping Current, I_{CLAMP} ⁽⁵⁾	$\pm 10mA$

- (1) Stresses beyond those listed may cause permanent device damage. Functional operation range of the device is defined in Recommended Operating Ratings or Electrical Characteristics. Exposure to absolute max ratings for extended periods may reduce device reliability.
- (2) Voltages are relative to GND pins.
- (3) As designed and characterized, not fully tested in production.
- (4) Applied voltage ratings may be exceeded if the clamping current ratings are observed.
- (5) Input terminal is clamped for input voltages above +10V or below -10V. Signals that swing more than 0.3V above +10V or 0.3V below -10V should be current limited to less than I_{CLAMP} .

Recommended Operating Ratings

$T_A = 25C$, unless otherwise specified.

Parameter	Symbol	Conditions	Min	Typ	Max	Unit
Output Voltage, Differential	V_{OUT}	Continuous	-5	-	5	V
Output Voltage, Common Mode	V_{CM}	WAVEGEN_RTN_SENSE to GND, continuous	-5	-	5	V
Output Current	I_{OUT}	Continuous	I_{OUT}	-	I_{+OUT}	mA

Electrical Characteristics⁽²⁾

$T_A = 25C$, $V_{SUPPLY} = 20V$, unless otherwise specified.

Parameter	Symbol	Conditions	Min	Typ	Max	Unit
Differential Output Voltage ⁽¹⁾⁽⁴⁾	V_{OUT}	WAVEGEN to WAVEGEN_RTN_SENSE	-5.0	-	+5.0	V
Output Current	I_{+OUT}	Sourcing	15	30	-	mA
	I_{-OUT}	Sinking	15	30	-	mA
Resolution			-	153	-	μV
Gain Error ⁽¹⁾⁽⁴⁾	GE	WAVEGEN_RTN_SENSE = 0V	-	-	0.1	%
Offset Error ⁽¹⁾⁽⁴⁾	MSE	$V_{CM} = 0V$, $V_{OUT} = 0V$	-	-	730	μV
Common Mode Range ⁽³⁾	V_{CM}	$\pm 5V$ square wave	± 8.5	± 10	-	V
Bandwidth	BW	$\pm 5V$ square wave	-	1.25	-	MHz
Positive Slew Rate	PSR	+5V to -5V; 10% to 90%	-	21	-	V/ μs
Negative Slew Rate	NSR	+5V to -5V; 90% to 10%	-	18	-	V/ μs
Sample Rate			-	-	1	MSPS

- (1) Parameter 100% production tested at $T_A = 25C$
- (2) As designed and characterized, not fully tested in production unless otherwise specified.
- (3) Applicable to WAVEGEN and WAVEGEN_RTN_SENSE individually.
- (4) Factory calibrated.

Source/Meter

The Source/Meter provides an adjustable voltage source with voltage and current measurement capability.

Applicable Pins: DC-62 pin 1.

Absolute Maximum Ratings⁽¹⁾⁽²⁾⁽³⁾

T_A = 25C, unless otherwise specified.

Description	Rating
Continuous Applied Voltage ⁽⁴⁾	-0.3V to +12.5V
Short Circuit	Continuous
Negative Clamping Current, I _{CLAMP} ⁽⁵⁾	100mA

- (1) Stresses beyond those listed may cause permanent device damage. Functional operation range of the device is defined in Recommended Operating Ratings or Electrical Characteristics. Exposure to absolute max ratings for extended periods may reduce device reliability.
- (2) Voltages are relative to GND pins.
- (3) As designed and characterized, not fully tested in production.
- (4) Applied voltage ratings may be exceeded if the clamping current ratings are observed.
- (5) Input terminal is diode-clamped to GND for input voltages that swing below GND. Signals that swing more than 0.2V below GND should be current limited to less than I_{CLAMP}.

Recommended Operating Ratings

T_A = 25C, unless otherwise specified.

Parameter	Conditions	Min	Typ	Max	Unit
Output Voltage, V _{OUT}	Continuous	0	-	10	V
Power Dissipation ⁽¹⁾ , P _D	Continuous	0	-	6	W

- (1) Power dissipation can be calculated by the following formula: $P_D = \frac{12.5V - V_{out}}{I_{out}}$.

Electrical Characteristics⁽²⁾

T_A = 25C, V_{SUPPLY} = 20V, unless otherwise specified.

Parameter	Symbol	Conditions	Min	Typ	Max	Unit
SOURCE						
Output Voltage ⁽¹⁾⁽³⁾	V _{OUT}		0	-	10	V
Resolution			-	2.7	-	mV
Gain Error ⁽¹⁾⁽³⁾		I _{OUT} = 0A	-	0.05	1	%
Offset Error ⁽¹⁾⁽³⁾		I _{OUT} = 0A	-	5	75	mV
Offset Error		I _{OUT} = 1.5A	-	-	250	mV
Output Impedance			-	0.1	-	Ω
Current Limit	I _{LIMIT}	V _{OUT} = 7V	1.5	2.7	-	A
Capacitance at Pin	C _P	Pin-to-ground	-	20	-	μF
VOLTAGE METER						
Gain Error ⁽¹⁾⁽³⁾			-	0.1	1	%
Offset Error ⁽¹⁾⁽³⁾			-	5	25	mV
CURRENT METER						
Gain Error ⁽¹⁾⁽³⁾		I _{OUT} = 1.0A	-	0.1	1	%
Offset Error ⁽¹⁾⁽³⁾			-	5	30	mA

- (1) Parameter 100% production tested at T_A = 25C
- (2) As designed and characterized, not fully tested in production unless otherwise specified.
- (3) Factory calibrated.

Negative Power DAC

The Negative Power DAC provides an adjustable negative voltage source.

Applicable Pins: DC-62 pin 2.

Absolute Maximum Ratings⁽¹⁾⁽²⁾⁽³⁾

$T_A = 25^\circ\text{C}$, unless otherwise specified.

Description	Rating
Continuous Applied Voltage ⁽⁴⁾	+0.3V to -12.5V
Short Circuit	Continuous
Positive Clamping Current, I_{+CLAMP} ⁽⁵⁾	100mA

(1) Stresses beyond those listed may cause permanent device damage. Functional operation range of the device is defined in Recommended Operating Ratings or Electrical Characteristics. Exposure to absolute max ratings for extended periods may reduce device reliability.

(2) Voltages are relative to GND pins.

(3) As designed and characterized, not fully tested in production.

(4) Applied voltage ratings may be exceeded if the clamping current ratings are observed.

(5) Input terminal is diode-clamped to GND for input voltages that swing above GND. Signals that swing more than 0.3V above GND should be current limited to less than I_{CLAMP} .

Recommended Operating Ratings

$T_A = 25^\circ\text{C}$, unless otherwise specified.

Parameter	Conditions	Min	Typ	Max	Unit
Output Voltage, V_{OUT}	Continuous	-10	-	0	V
Output Current, I_{OUT}	Continuous	-100	-	0	mA

Electrical Characteristics⁽²⁾

$T_A = 25^\circ\text{C}$, $V_{SUPPLY} = 20\text{V}$, unless otherwise specified.

Parameter	Symbol	Conditions	Min	Typ	Max	Unit
Output Voltage ⁽¹⁾⁽³⁾	V_{OUT}		-10	-	0	V
Resolution			-	2.7	-	mV
Gain Error ⁽¹⁾⁽³⁾		$I_{OUT} = 0\text{A}$	-	0.25	1.5	%
Offset Error ⁽¹⁾⁽³⁾		$I_{OUT} = 0\text{A}$	-	25	100	mV
Current Limit ⁽¹⁾	I_{LIMIT}		-320	-200	-100	mA
Capacitance at Pin	C_P	Pin-to-ground	-	20	-	μF

(1) Parameter 100% production tested at $T_A = 25^\circ\text{C}$

(2) As designed and characterized, not fully tested in production unless otherwise specified.

(3) Factory calibrated.

Power Meters

The Power Meters provide voltage and current measurement capability.

Applicable Pins: DC-62 pin 3 - 10.

Absolute Maximum Ratings⁽¹⁾⁽²⁾⁽³⁾

T_A = 25C, unless otherwise specified.

Description	Rating
Continuous Applied Voltage, any pin to GND	-48V to +48V
Current Meter 0 Applied Current	300 mA
Current Meter 1 Applied Current	3.0 A

- (1) Stresses beyond those listed may cause permanent device damage. Functional operation range of the device is defined in Recommended Operating Ratings or Electrical Characteristics. Exposure to absolute max ratings for extended periods may reduce device reliability.
- (2) Voltages are relative to GND pins unless otherwise specified.
- (3) As designed and characterized, not fully tested in production.

Recommended Operating Ratings

T_A = 25C, unless otherwise specified.

Parameter	Conditions	Min	Typ	Max	Unit
VOLTAGE METER 0, 1					
Differential Input Voltage	Continuous	-13.5	-	13.5	V
Common Mode Input Voltage, V _{CM}	Continuous	-45	-	+45	V
CURRENT METER 0					
Input Current	Continuous	-150	-	+150	mA
Common Mode Input Voltage, V _{CM}	Continuous	-45	-	+45	V
CURRENT METER 1					
Input Current	Continuous	-1.5	-	1.5	A
Common Mode Input Voltage, V _{CM}	Continuous	-45	-	+45	V

Electrical Characteristics⁽²⁾⁽⁴⁾

T_A = 25C, V_{SUPPLY} = 20V, unless otherwise specified.

Parameter	Symbol	Conditions	Min	Typ	Max	Unit
VOLTAGE METER 0, 1						
Gain Error ⁽¹⁾⁽³⁾		V _{CM} = 0	-	0.1	0.5	%
Offset Error ⁽¹⁾⁽³⁾		V _{CM} = 0	-	5	25	mV
CURRENT METER 0						
Gain Error ⁽¹⁾⁽³⁾		V _{CM} = 0	-	0.1	1	%
Offset Error ⁽¹⁾⁽³⁾		V _{CM} = 0	-	0.8	2	mA
CURRENT METER 1						
Gain Error ⁽¹⁾⁽³⁾		V _{CM} = 0	-	0.5	1.5	%
Offset Error ⁽¹⁾⁽³⁾		V _{CM} = 0	-	2	15	mA

- (1) Parameter 100% production tested at T_A = 25C
- (2) As designed and characterized, not fully tested in production unless otherwise specified.
- (3) Factory calibrated.
- (4) V_{CM} = 0 indicates the negative terminal is grounded.

DIOs

There are 8 DIOs (Digital Input/Outputs) on the board. They can be configured all as 3.3V CMOS level or 5V CMOS level. There are two banks of four DIOs. Each bank can be configured as an input or as an output.

Applicable Pins: DC-62 pins 23-30.

Absolute Maximum Ratings⁽¹⁾⁽²⁾⁽³⁾

$T_A = 25C$, unless otherwise specified.

Description	Rating
Continuous Applied Voltage, configured as 3.3V DIOs ⁽⁴⁾	-0.3V to +3.6V
Continuous Applied Voltage, configured as 5.0V DIOs ⁽⁴⁾	-0.3V to +5.4V
Output Current	$\pm 50mA$
Positive Clamping Current, I_{+CLAMP} ⁽⁵⁾	50mA
Negative Clamping Current, I_{-CLAMP} ⁽⁶⁾	50mA

(1) Stresses beyond those listed may cause permanent device damage. Functional operation range of the device is defined in Recommended Operating Ratings or Electrical Characteristics. Exposure to absolute max ratings for extended periods may reduce device reliability.

(2) Voltages are relative to GND pins.

(3) As designed and characterized, not fully tested in production.

(4) Applied voltage ratings may be exceeded if the clamping current ratings are observed.

(5) Input terminal is diode-clamped to the selected DIO voltage for input voltages that swing above the selected DIO voltage. Signals that exceed the applied voltage rating must be current limited to less than I_{+CLAMP} .

(6) Input terminal is diode-clamped to GND for input voltages that swing below GND. Signals that negatively exceed the applied voltage must be current limited to less than I_{-CLAMP} .

Recommended Operating Ratings

$T_A = 25C$, unless otherwise specified.

Parameter	Conditions	Min	Typ	Max	Unit
Continuous Applied Voltage	configured as 3.3V DIOs	0	-	3.3	V
Continuous Applied Voltage	configured as 5.0V DIOs	0	-	5.0	V
Output Current		0	-	20	mA

Electrical Characteristics⁽²⁾

$T_A = 25C$, $V_{SUPPLY} = 20V$, unless otherwise specified.

Parameter	Symbol	Conditions	Min	Typ	Max	Unit
Configured as 3.3V DIOs						
Logic High Input Voltage	V_{IH}		2.0	-	-	V
Logic Low Input Voltage	V_{IL}		-	-	0.8	V
Logic High Output Voltage	V_{OH}	$I_O = -10mA$	2.6	-	-	V
Logic Low Output Voltage	V_{OL}	$I_O = 10mA$	-	-	0.55	V
Output Impedance	R_{OUT}		-	60	-	Ω
Configured as 5.0V DIOs						
Logic High Input Voltage	V_{IH}		3.6	-	-	V
Logic Low Input Voltage	V_{IL}		-	-	1.5	V
Logic High Output Voltage	V_{OH}	$I_O = -10mA$	4.0	-	-	V
Logic Low Output Voltage	V_{OL}	$I_O = 10mA$	-	-	0.55	V
Output Impedance	R_{OUT}		-	60	-	Ω

(1) Parameter 100% production tested at $T_A = 25C$

(2) As designed and characterized, not fully tested in production unless otherwise specified.

Isolated Input

There are 2 differential, 5V-33V, Isolated Inputs on this deck. ISOLATED_INPUT_[0-1] and ISOLATED_INPUT_[0-1]_RTN are available on J1.

Voltages in the range of 5V-33V between ISOLATED_INPUT_[0-1] and ISOLATED_INPUT_[0-1]_RTN are registered as a high.

Theory of Operation: The isolated input are differential for high common mode noise immunity and filtered for high differential noise immunity. The inputs are isolated from circuit ground to eliminate ground loops. These isolated inputs can be used to detect discrete voltages in noisy environments without false tripping.

Applicable Pins: DC-62 pins 36, 37, 56, 57.

Absolute Maximum Ratings⁽¹⁾⁽²⁾⁽³⁾

T_A = 25C, unless otherwise specified.

Description	Rating
Continuous Applied Voltage, ISOLATED_INPUT to ISOLATED_INPUT_RTN	-33V to 33V
Any pin to GND	±50V

(1) Stresses beyond those listed may cause permanent device damage. Functional operation range of the device is defined in Recommended Operating Ratings or Electrical Characteristics. Exposure to absolute max ratings for extended periods may reduce device reliability.

(2) Voltages are relative to GND pins unless otherwise specified.

(3) As designed and characterized, not fully tested in production.

Recommended Operating Ratings

T_A = 25C, unless otherwise specified.

Parameter	Conditions	Min	Typ	Max	Unit
Continuous Applied Voltage	ISOLATED_INPUT to ISOLATED_INPUT_RTN	-30		+30	V
Any pin to GND		-50		+50	V

Electrical Characteristics⁽²⁾

T_A = 25C, V_{SUPPLY} = 20V, unless otherwise specified.

Parameter	Symbol	Conditions	Min	Typ	Max	Unit
Logic High Input Voltage	V _{IH}	ISOLATED_INPUT to ISOLATED_INPUT_RTN	5	-	-	V
Logic Threshold Level	V _{TH}		-	1.7	-	V
Logic Low Input Voltage	V _{IL}	ISOLATED_INPUT to ISOLATED_INPUT_RTN	-	-	0.8	V
Turn-on Propagation Delay	t _{PLH}	Transition from 0V to 5V	-	30	-	μs
Turn-off Propagation Delay	t _{PHL}	Transition from 5V to 0V	-	650	-	μs
High-level Input Current	I _{IH}	V _{IH} = 5V	-	1.0	-	mA
		V _{IH} = 28V	-	6.8	-	mA

(1) Parameter 100% production tested at T_A = 25C

(2) As designed and characterized, not fully tested in production unless otherwise specified.

Solid State Relay

There are two solid-state relays. These relays provide isolated switching through MOSFET-based solid-state relays that can pass AC or DC signals.

Applicable Pins: DC-62, pins 46, 47, 48, 49.

Absolute Maximum Ratings⁽¹⁾⁽²⁾⁽³⁾

$T_A = 25^\circ\text{C}$, unless otherwise specified.

Description	Rating
Voltage, RELAY _x _SSR_NO to RELAY _x _SSR_COM	-45V to 45V
Continuous Applied Voltage, any pin to GND	$\pm 50\text{V}$
Continuous Current, RELAY _x _SSR_NO to RELAY _x _SSR_COM	50mA

(1) Stresses beyond those listed may cause permanent device damage. Functional operation range of the device is defined in Recommended Operating Ratings or Electrical Characteristics. Exposure to absolute max ratings for extended periods may reduce device reliability.

(2) Voltages are relative to GND pins unless otherwise specified.

(3) As designed and characterized, not fully tested in production.

Recommended Operating Ratings

$T_A = 25^\circ\text{C}$, unless otherwise specified.

Parameter	Conditions	Min	Typ	Max	Unit
Voltage	Off State	-45	-	45	V
Current	On State	0	-	50	mA

Electrical Characteristics⁽²⁾

$T_A = 25^\circ\text{C}$, $V_{\text{SUPPLY}} = 20\text{V}$, unless otherwise specified.

Parameter	Symbol	Conditions	Min	Typ	Max	Unit
On-state Resistance	R_{ON}	$I_{\text{ON}} = 50\text{mA}$	-	2	10	Ω
Off-state Current	I_{OFF}	$V_{\text{OFF}} = 45\text{V}$	-	-	5	μA
Off-state Capacitance	C_{OFF}	$V = 0, f = 1\text{ MHz}$	-	90	-	pF
Turn-on Time	t_{ON}	$R_S = 200\ \Omega, V = 20\text{V}$	-	1.4	-	ms
Turn-off Time	t_{OFF}		-	0.6	-	ms

(1) Parameter 100% production tested at $T_A = 25^\circ\text{C}$

(2) As designed and characterized, not fully tested in production unless otherwise specified.

Solenoid Driver

There are 4 solenoid drivers on this Deck. The solenoid driver is a low side switch designed to switch inductive, resistive or capacitive loads to ground.

Theory of Operation: When asserted, the SOLENOID_DRIVER_[0-3] line will be shorted to ground. When de-asserted, the SOLENOID_DRIVER_[0-3] line will be in a high impedance state. If the die temp exceeds 150C or the current limit is exceeded, the SOLENOID_DRIVER_[0-3] line will latch off until the command is cycled.

Voltage Clamp: The solenoid driver has a clamp to limit the voltage spike due to switching off inductive loads.

Over Current Protection: The solenoid driver has over current protection that will disable the solenoid driver. The solenoid driver will remain disabled until commanded off then on again.

Applicable Pins: DC-62 pins 51, 50, 45, 44 (SOLENOID_DRIVER0 – SOLENOID_DRIVER3).

Absolute Maximum Ratings⁽¹⁾⁽²⁾⁽³⁾

T_A = 25C, unless otherwise specified.

Description	Rating
Continuous Applied Voltage ⁽⁴⁾	-0.5V to 41V
Positive Unclamped Single Pulse Inductive Energy, E _{AS} ⁽⁵⁾	65mJ
Negative Clamping Current, I _{CLAMP} ⁽⁶⁾	350mA

(1) Stresses beyond those listed may cause permanent device damage. Functional operation range of the device is defined in Recommended Operating Ratings or Electrical Characteristics. Exposure to absolute max ratings for extended periods may reduce device reliability.

(2) Voltages are relative to GND pins.

(3) As designed and characterized, not fully tested in production.

(4) Applied voltage ratings may be exceeded if the clamping current ratings are observed.

(5) Input terminal is actively clamped for input voltages that swing above V_{DS}. Signals that swing above V_{DS} should be energy limited to less than E_{AS}.

(6) Input terminal is diode-clamped to GND for input voltages that swing below GND. Signals that swing more than 0.5V below GND should be current limited to less than I_{CLAMP}.

Recommended Operating Ratings

T_A = 25C, unless otherwise specified.

Parameter	Conditions	Min	Typ	Max	Unit
Pin Voltages		-0.3		36	V
Continuous Driver Current, I _D		0		0.6	A

Electrical Characteristics⁽²⁾

T_A = 25C, V_{SUPPLY} = 20V, unless otherwise specified.

Parameter	Symbol	Conditions	Min	Typ	Max	Unit
Driver Current	I _D	V _{DS} = 0-41V	-	-	0.75	A
Driver Voltage	V _{DS}	Clamp not active	-	-	41	V
Clamping Voltage	V _{DS(AZ)}	I _D = 10mA	41	-	50	V
Current Limit	I _{D(OVL)}		0.75	-	1.5	A
Leakage Current	I _{DSS}	V _{DS} = 36V	-	2.5	6	μA
On-State Resistance	R _{DSON}	I _D = 350mA	-	1.5	-	Ω

(1) Parameter 100% production tested at T_A = 25C

(2) As designed and characterized, not fully tested in production unless otherwise specified.

AC Measurement

The AC Measurement will allow the measurement of an AC signal while rejecting the DC Component.

Theory of Operation: The measurement bandwidth is 20Hz to 300kHz with a max input of $\pm 300\text{mVpk}$. This allows for measurement of small signals such as noise on a DC signal.

Applicable Pins: DC-62 pin 54 and 55.

Absolute Maximum Ratings⁽¹⁾⁽²⁾⁽³⁾

$T_A = 25\text{C}$, unless otherwise specified.

Description	Rating
Continuous Applied Voltage, any pin to GND	-48V to +48V

- (1) Stresses beyond those listed may cause permanent device damage. Functional operation range of the device is defined in Recommended Operating Ratings or Electrical Characteristics. Exposure to absolute max ratings for extended periods may reduce device reliability.
 (2) Voltages are relative to GND pins unless otherwise specified.
 (3) As designed and characterized, not fully tested in production.

Recommended Operating Ratings

$T_A = 25\text{C}$, unless otherwise specified.

Parameter	Conditions	Min	Typ	Max	Unit
Differential Input Voltage	Continuous	-45	-	+45	V

Electrical Characteristics⁽²⁾⁽⁴⁾

$T_A = 25\text{C}$, $V_{\text{SUPPLY}} = 20\text{V}$, unless otherwise specified.

Parameter	Symbol	Conditions	Min	Typ	Max	Unit
Gain Error ⁽¹⁾⁽³⁾		$V_{\text{CM}} = 0$	-	0.5	1.5	%
Offset Error ⁽¹⁾⁽³⁾		$V_{\text{CM}} = 0$	-	5	25	mV
Input Impedance	R_{IN}	50ohm Termination Disabled	-	4	-	k Ω
		50ohm Termination Enabled	-	50	-	Ω

- (1) Parameter 100% production tested at $T_A = 25\text{C}$
 (2) As designed and characterized, not fully tested in production unless otherwise specified.
 (3) Factory calibrated.
 (4) $V_{\text{CM}} = 0$ indicates the negative terminal is grounded.

Information provided is believed to be reliable and accurate. Subinitial LLC assumes no responsibility for consequences of using such information nor infringement of patents or other rights of 3rd parties which may result from its use. No license is granted by any means under any patent or patent rights of Subinitial LLC. Specifications mentioned in this document are subject to change without notice. This document supersedes and replaces all information previously supplied. Subinitial LLC products are not authorized for use as critical components in life support devices or systems and/or safety applications without express written approval of Subinitial LLC.

©Subinitial LLC